

US008599113B2

(12) **United States Patent**  
**Lhee et al.**

(10) **Patent No.:** **US 8,599,113 B2**  
(45) **Date of Patent:** **Dec. 3, 2013**

(54) **ORGANIC LIGHT EMITTING DISPLAY  
DEVICE AND METHOD OF  
MANUFACTURING THE SAME**

2005/0151462	A1	7/2005	Miyagawa
2006/0024855	A1	2/2006	Sano
2006/0170339	A1	8/2006	Kanno et al.
2006/0246620	A1	11/2006	Nagayama et al.
2007/0063636	A1	3/2007	Guenther et al.
2008/0204377	A1*	8/2008	Kajiyama et al. .... 345/76
2008/0224607	A1	9/2008	Matsuo et al.

(75) Inventors: **Zail Lhee**, Yongin (KR); **Sang-Mok Hong**, Yongin (KR)

(73) Assignee: **Samsung Display Co., Ltd.** (KR)

**FOREIGN PATENT DOCUMENTS**

(\*) Notice: Subject to any disclaimer, the term of this patent is extended or adjusted under 35 U.S.C. 154(b) by 424 days.

CN	1905204	1/2007
JP	08-222371	8/1996
JP	2001109399	4/2001
JP	2001-189192	7/2001
JP	2001-244073	9/2001
JP	2002246185	8/2002
JP	2002-324672	11/2002
JP	2004-205690	7/2004
JP	2005518080	6/2005
JP	2005-203351	7/2005
JP	2005-317382	11/2005

(21) Appl. No.: **12/553,894**

(22) Filed: **Sep. 3, 2009**

(65) **Prior Publication Data**

US 2010/0117936 A1 May 13, 2010

(Continued)

(30) **Foreign Application Priority Data**

Nov. 10, 2008 (KR) ..... 10-2008-0110924

**OTHER PUBLICATIONS**

Office Action dated Sep. 20, 2011, received in Japanese Patent Application No. 2009-033187, claiming priority to Korean priority application 10-2008-0110924.

Office Action dated Apr. 29, 2010 in KR priority application No. 10-2008-0110924.

(51) **Int. Cl.**  
**G09G 3/32** (2006.01)

(52) **U.S. Cl.**  
USPC ..... **345/76**

(Continued)

(58) **Field of Classification Search**  
None  
See application file for complete search history.

*Primary Examiner* — Joseph Haley  
(74) *Attorney, Agent, or Firm* — Knobbe Martens Olson & Bear LLP

(56) **References Cited**

**U.S. PATENT DOCUMENTS**

6,146,715	A	11/2000	Kim et al.
6,204,610	B1*	3/2001	Komiya ..... 345/76
2002/0145381	A1	10/2002	Humbs
2003/0006699	A1	1/2003	Ogino et al.
2005/0001546	A1	1/2005	Yamaguchi
2005/0012094	A1	1/2005	Park
2005/0035708	A1	2/2005	Yamazaki et al.
2005/0142975	A1	6/2005	Lee et al.

(57) **ABSTRACT**

An organic light emitting display device and a method of manufacturing the same are disclosed. The organic light emitting display device includes a substrate on which first, second and third pixel units are arranged in row and column directions. To simplify manufacturing and reduce defects, the first, second and third pixel units are arranged so that each column of the display is formed of only one of the first, second, and third pixel units.

**4 Claims, 5 Drawing Sheets**

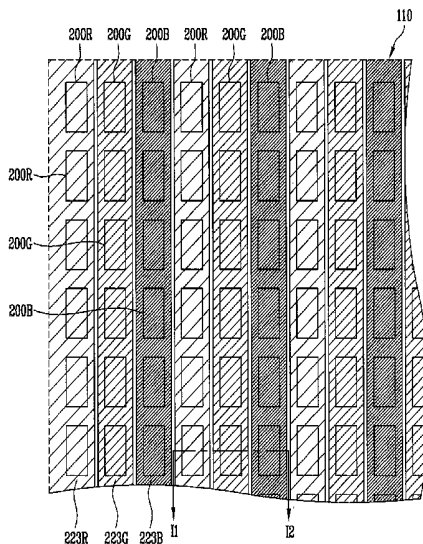

(56)

**References Cited**

FOREIGN PATENT DOCUMENTS

JP	2007503686	2/2007
JP	2007234232	9/2007
JP	2007-311238	11/2007
JP	2008041747	2/2008
JP	2008-251270	10/2008
KR	10-2000-0073038	12/2000
KR	10-2006-0055941	5/2006
KR	10-2006-0058458	5/2006
KR	10-2007-0112447 A	11/2007
TW	I232700	1/2005
TW	I286385	9/2007

OTHER PUBLICATIONS

Oct. 28, 2010 Office Action in priority Korean Patent Application No. 10-2008-0110924.  
Office Action dated Jan. 17, 2012 in corresponding Japanese Patent Application No. 2009-033187.  
Chinese Office Action in the corresponding Chinese Patent Application No. 200910212119.4 dated Jun. 16, 2011.  
Office Action dated May 15, 2012 in corresponding Japanese Patent Application No. 2009-033187.  
Office Action dated May 22, 2013 in corresponding Taiwanese Patent Application No. 098134085.  
EPO Communication dated Mar. 27, 2013 in corresponding European Patent Application No. 09175501.7.

\* cited by examiner

FIG. 1A

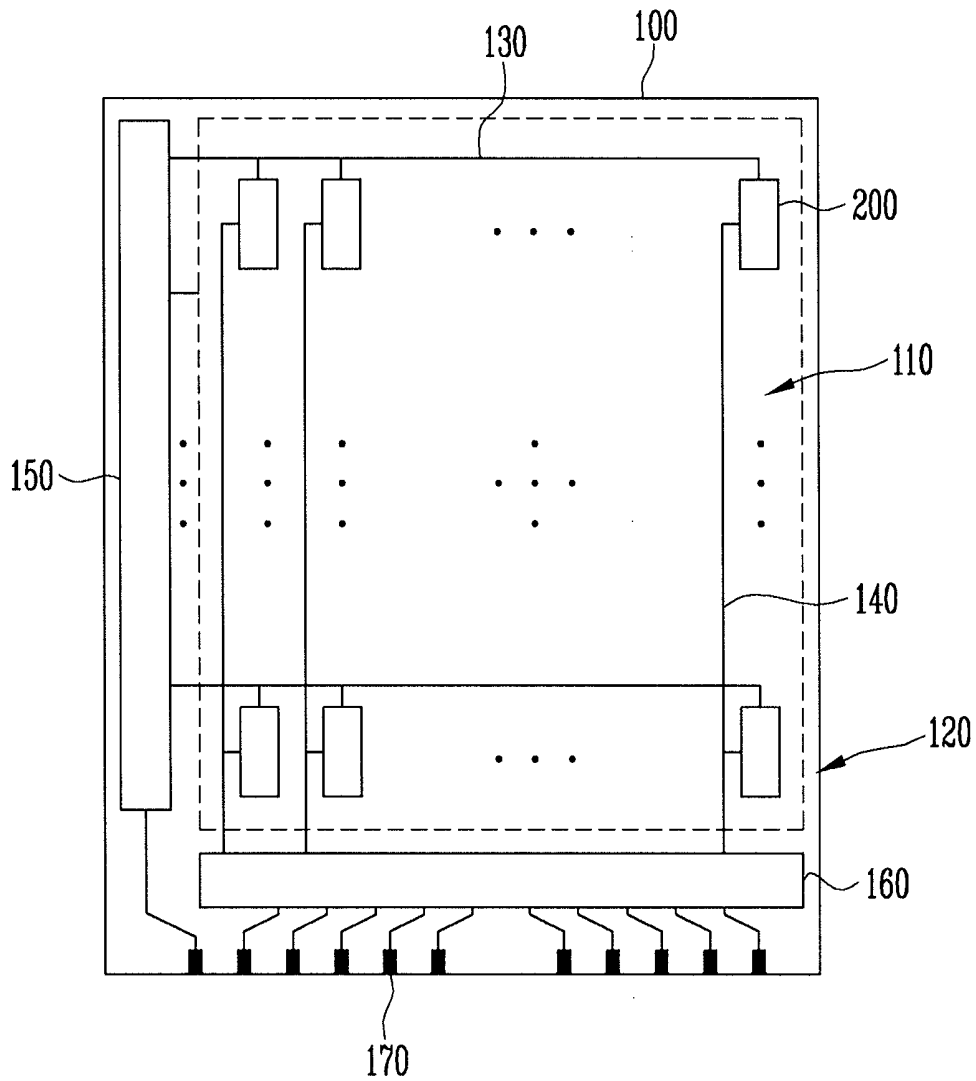

FIG. 1B

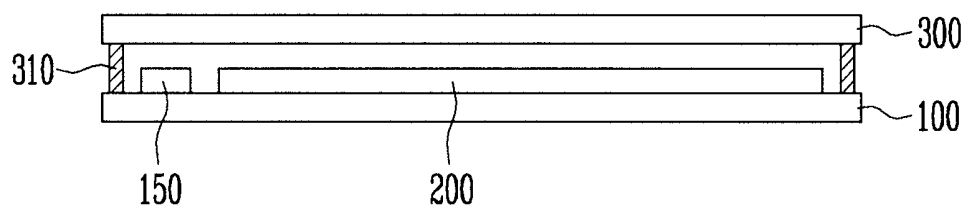

FIG. 2

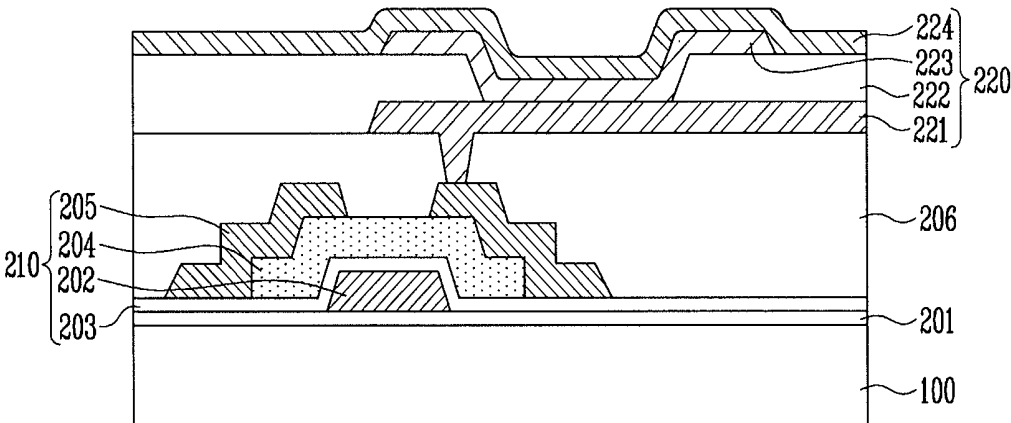

FIG. 3

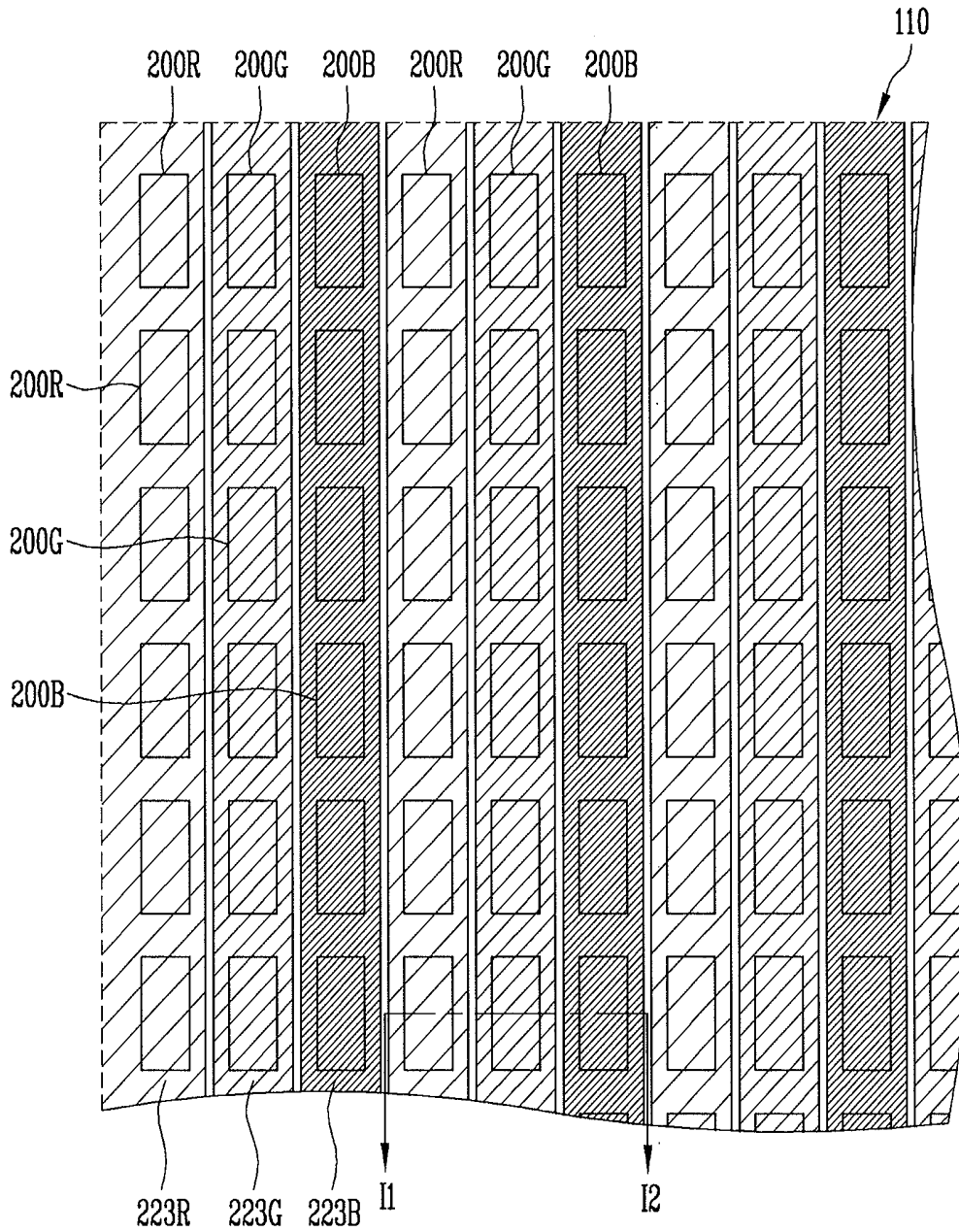

FIG. 4A

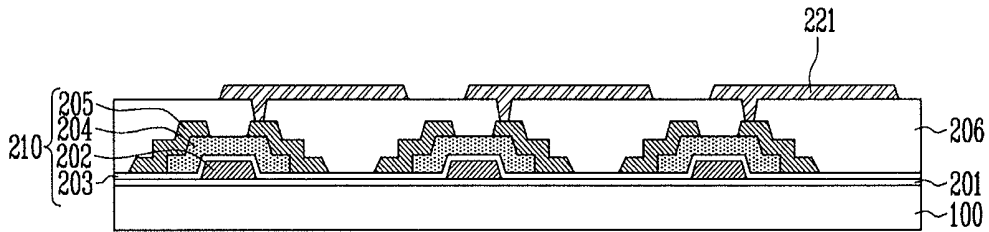

FIG. 4B

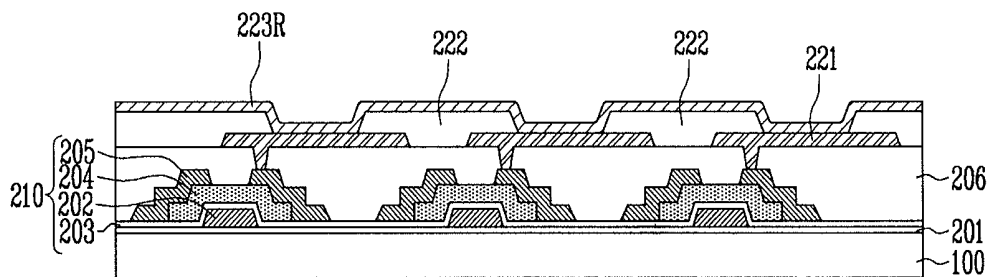

FIG. 4C

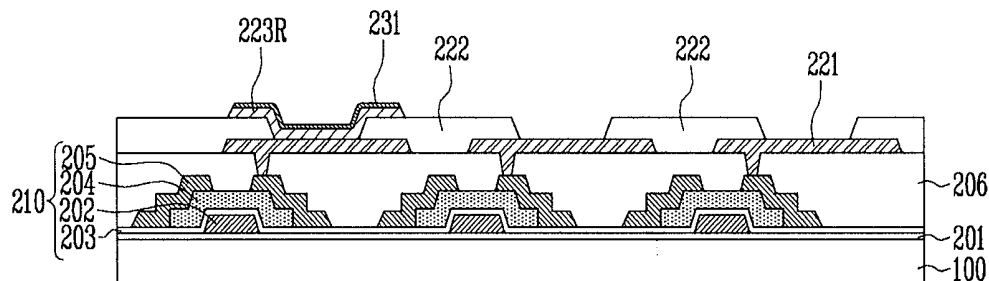

FIG. 4D

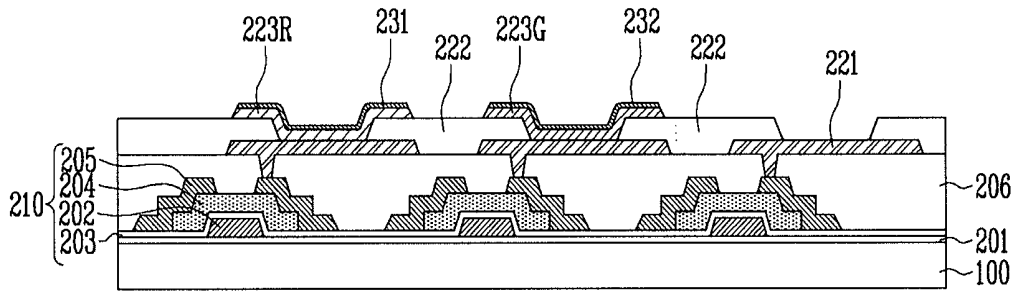

FIG. 4E

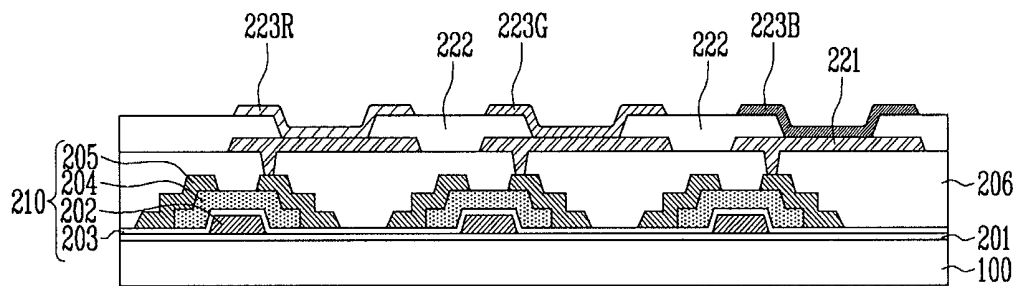
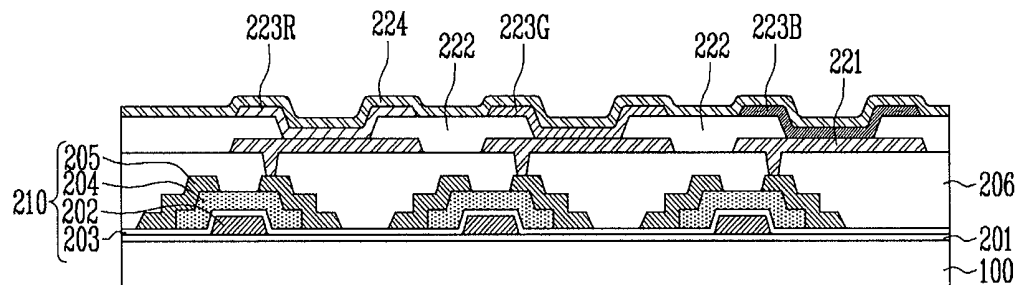

FIG. 4F



**ORGANIC LIGHT EMITTING DISPLAY  
DEVICE AND METHOD OF  
MANUFACTURING THE SAME**

**CROSS-REFERENCE TO RELATED  
APPLICATIONS**

This application claims priority to and the benefit of Korean Patent Application No. 10-2008-0110924, filed on Nov. 10, 2008, in the Korean Intellectual Property Office, the entire content of which is incorporated herein by reference.

**BACKGROUND**

**1. Field**

The field relates to an organic light emitting display device and a method of manufacturing the same, and more particularly, to an organic light emitting display device and a method of manufacturing the same in which an organic light emitting layer can be easily formed and manufacturing defects can be minimized.

**2. Description of the Related Technology**

An organic light emitting display device is a next-generation display device having self-luminescent characteristics. The organic light emitting display device has superior characteristics when compared to a liquid crystal display device (LCD) in view of viewing angle, contrast, response speed and power consumption.

An organic light emitting diode of a pixel of an organic light emitting display device includes an anode electrode, a cathode electrode and an organic light emitting layer. The organic light emitting diode emits light as the result of the recombination in the organic light emitting layer of holes and electrons injected through the anode and cathode electrodes respectively.

Generally, an organic light emitting layer of an organic light emitting device is formed by a vacuum deposition method using a shadow mask. A shadow mask has been disclosed in Korean Patent Publication No. 10-2004-0042179 (May 20, 2004). For selective deposition of an organic material, dot- or substantially rectangular-shaped openings are formed in the shadow mask.

However, in the conventional method using a shadow mask, when the shadow mask is thin, it is difficult to deposit the organic material into a precise pattern (shape) due to bending of the shadow mask. When the shadow mask is thick, the organic material may not be deposited at certain portions because of an evaporation angle of the organic material. In a full-color display device, mask alignment and deposition processes are performed several times so as to form respective red, green and blue light emitting layers. For this reason, the manufacturing process is complicated, and defects caused by contamination are produced.

**SUMMARY OF CERTAIN INVENTIVE ASPECTS**

One aspect is an organic light emitting display device, including a substrate including a plurality of areas arranged in row and column directions, where each column of areas is designated for one of first, second and third pixel units, an insulating layer formed in the areas, a plurality of first electrodes formed on the insulating layer, where each electrode is formed in one of the areas, a first light emitting layer formed on the first electrodes in the column of the first pixel units, a second light emitting layer formed on the first electrodes in the column of the second pixel units, a third light emitting layer formed on the first electrodes in the column of the third

pixel units, and a second electrode formed on the first, second, and third light emitting layers.

Another aspect is an organic light emitting display device, including a substrate including a plurality of areas arranged in row and column directions, where each column of areas is designated for one of first, second and third pixel units, a plurality of first electrodes formed on the areas where each electrode is formed in one of the areas, a pixel defining layer formed on the substrate, where the pixel defining layer is patterned to expose the first electrodes, a first light emitting layer formed on the first electrodes in the column of the first pixel units, a second light emitting layer formed on the first electrodes in the column of the second pixel units, a third light emitting layer formed on the first electrodes in the column of the third pixel units, and a second electrode formed on the first, second, and third light emitting layers.

Another aspect is a method of manufacturing an organic light emitting display device, including providing a substrate including a plurality of areas arranged in row and column directions, where each column of areas is designated for one of first, second and third pixel units, forming an insulating layer in the areas, forming a plurality of first electrodes on the insulating layer, where each electrode is formed in one of the areas, forming a first light emitting layer on the substrate, removing at least a portion of the first light emitting layer in areas other than in the column of first pixel units, forming a second light emitting layer on the substrate, removing at least a portion of the second light emitting layer formed in areas other than in the column of the second pixel units, forming a third light emitting layer on the substrate, removing at least a portion of the third light emitting layer formed in areas other than in the column of the second pixel units, and forming a second electrode on the first, second and third light emitting layers.

Another aspect is a method of manufacturing an organic light emitting display device, including providing a substrate including a plurality of areas arranged in row and column directions, where each column of areas is designated for one of first, second and third pixel units, forming a plurality of first electrodes on the areas where each electrode is formed in one of the areas, forming a pixel defining layer on the substrate, patterning the pixel defining layer to expose the first electrodes, forming a first light emitting layer on the substrate, removing at least a portion of the first light emitting layer in areas other than in the column of first pixel units, forming a second light emitting layer on the substrate, removing at least a portion of the second light emitting layer in areas other than in the column of second pixel units, forming a third light emitting layer on the substrate, removing at least a portion of the third light emitting layer in areas other than in the column of third pixel units, and forming a second electrode on the first, second and third light emitting layers.

**BRIEF DESCRIPTION OF THE DRAWINGS**

The accompanying drawings, together with the specification, illustrate exemplary embodiments.

FIGS. 1A and 1B are a schematic plan view and a cross-sectional view of an organic light emitting display device according to an embodiment.

FIG. 2 is a cross-sectional view of a pixel unit shown in FIG. 1A.

FIG. 3 is a schematic plan view of a pixel region illustrating an organic light emitting layer of the pixel unit of FIG. 2.

FIGS. 4A to 4F are cross-sectional views illustrating a method of manufacturing an organic light emitting display device according to an embodiment.

#### DETAILED DESCRIPTION OF CERTAIN INVENTIVE ASPECTS

Certain embodiments provide an organic light emitting display device and a method of manufacturing the same in which an organic light emitting layer can be easily formed.

Certain embodiments also provide an organic light emitting display device and a method of manufacturing the same in which a defect rate can be minimized.

According to one aspect, an organic light emitting display device is disclosed. The device includes a substrate on which first, second and third pixel units are arranged in row and column directions; an insulating layer formed on the substrate having the first, second and third pixel units; first electrodes formed on the insulating layer having the first, second and third pixel units; a first light emitting layer formed on the first electrodes in the column of the first pixel units and the insulating layer; a second light emitting layer formed on the first electrodes in the column of the second pixel units and the insulating layer; a third light emitting layer formed on the first electrodes in the column of the third pixel units and the insulating layer; and a second electrode formed on the substrate having the first, second and third light emitting layers.

According to another aspect, an organic light emitting display device is disclosed. The device includes a substrate on which first, second and third pixel units are arranged in row and column directions; first electrodes formed on the substrate having the first, second and third pixel units; a pixel defining layer formed on the substrate having the first electrodes, the pixel defining layer being patterned to expose the first electrodes; a first light emitting layer formed on the first electrodes in the column of the first pixel units and the pixel defining layer; a second light emitting layer formed on the first electrodes in the column of the second pixel units and the pixel defining layer; a third light emitting layer formed on the first electrodes in the column of the third pixel units and the pixel defining layer; and a second electrode formed on the substrate having the first, second and third light emitting layers.

According to still another aspect, a method of manufacturing an organic light emitting display device is disclosed. The method includes providing a substrate on which first, second and third pixel units are arranged in row and column directions; forming an insulating layer on the substrate having the first, second and third pixel units; forming first electrodes on the insulating layer having the first, second and third pixel units; forming a first light emitting layer on an entire surface of the substrate and then removing the first light emitting layer formed on the first electrodes in the columns of the second and third pixel units and the insulating layer; forming a second light emitting layer on the entire surface of the substrate and then removing the second light emitting layer formed on the first light emitting layer in the column of the first pixel units, the first electrodes in the column of the third pixel units and the insulating layer; forming a third light emitting layer on the entire surface of the substrate and then removing the third light emitting layer formed on the first light emitting layer in the column of the first pixel units and the second light emitting layer in the column of the second pixel units; and forming a second electrode on the substrate having the first, second and third light emitting layers.

According to still another aspect, a method of manufacturing an organic light emitting display device is disclosed. The

method includes providing a substrate on which first, second and third pixel units are arranged in row and column directions; forming first electrodes on the substrate having the first, second and third pixel units; forming a pixel defining layer on the substrate having the first electrodes and then exposing the first electrodes; forming a first light emitting layer on an entire surface of the substrate and then removing the first light emitting layer formed on the first electrodes in the columns of the second and third pixel units and the pixel defining layer; forming a second light emitting layer on the entire surface of the substrate and then removing the second light emitting layer formed on the first light emitting layer on in column of the first pixel units, the first electrodes in the column of the third pixel units and the pixel defining layer; forming a third light emitting layer on the entire surface of the substrate and then removing the third light emitting layer formed on the first light emitting layer in the column of the first pixel units and the second light emitting layer in the column of the second pixel units; and forming a second electrode on the substrate having the first, second and third light emitting layers.

According to certain embodiments, organic light emitting layers are formed in a substantially rectangular shape in the columns of respective pixel units by patterning red, green and blue light emitting layer using a laser. A mask having openings is used to expose the entire pixel region, so that the mask can be easily manufactured. Since the red, green and blue light emitting layers are all formed using a mask, manufacturing cost can be saved. Further, the red, green and blue light emitting layers are selectively removed using a laser, so that the organic light emitting layers can be formed in a precise pattern (shape), and a defect ratio due to contamination can be prevented.

Only certain exemplary embodiments are shown and described, simply by way of illustration. As those skilled in the art would realize, the described embodiments may be modified in various ways, without departing from the spirit or scope of the present invention. Accordingly, the drawings and description are to be regarded as illustrative in nature and not restrictive. In addition, when an element is referred to as being "on" another element, the element can be directly on the another element or be indirectly on the another element with one or more intervening elements interposed therebetween. Also, when an element is referred to as being "connected to" another element, it can be directly connected to the another element or be indirectly connected to the another element with one or more intervening elements interposed therebetween. Hereinafter, like reference numerals generally refer to like elements.

FIGS. 1A and 1B are a schematic plan view and a cross-sectional view of an organic light emitting display device according to an embodiment.

Referring to FIG. 1A, a substrate 100 has a pixel region 110 and a non-pixel region 120. In this embodiment, the non-pixel region 120 is a region surrounding the pixel region 110 or the region excluding the pixel region 110 on the substrate 100.

A plurality of pixel units 200 including light emitting devices connected in a matrix form between scan and data lines 130 and 140 are arranged in a pixel region 110 on the substrate 100. The plurality of pixel units 200 are arranged in column and row directions and include red, green and blue pixel units. For example, red, green and blue pixels may be sequentially and repeatedly arranged in a row direction, and red, green or blue pixels may be consecutively arranged.

In the non-pixel region 120 on the substrate 100 scan and data lines 130 and 140 respectively are disposed in the pixel region 110. Power supply lines (not shown) supply power for operating the light emitting devices and scan and data driving

units **150** and **160** process signals provided from the outside of the organic light emitting display device through pads **170**. The scan and data driving units **150** and **160** include driving circuits that convert signals provided from the outside of the organic light emitting display device through the pads **170** into scan and data signals, thereby selectively driving the respective pixels.

Referring to FIG. **1b**, a sealing substrate **300** sealing the pixel region **110** is disposed above the substrate **100** having the plurality of pixel units **200**. The sealing substrate **300** and the substrate **100** are joined together by a sealing member **310**.

FIG. **2** is a cross-sectional view of an embodiment of a pixel unit **200** shown in FIG. **1A**. The pixel unit of FIG. **2** includes a light emitting device, a thin film transistor (TFT) to control the operation of the light emitting device, and a capacitor to maintain a signal. However, only the TFT and the light emitting device are shown herein for convenience of illustration.

Referring to FIG. **2**, the light emitting device **220** includes an anode electrode **221**, a cathode electrode **224**, and an organic light emitting layer **223** interposed between the anode and cathode electrodes **221** and **224**.

Anode electrodes **221** are formed in the plurality of pixel units **200** on the substrate **100**. The organic light emitting layer **223** is formed in a light emitting region (a region to which the anode electrode **221** is exposed), defined by a pixel defining layer **222**. The organic light emitting layer **223** may include a hole injection layer, a hole transfer layer, an electron transfer layer and an electron injection layer. The cathode layer **224** is formed on the organic light emitting layer **223** in the pixel unit **200**.

The TFT **210** includes a semiconductor layer **204** providing source and drain regions and a channel region, a gate electrode **202** isolated from the semiconductor layer **204** by a gate insulating layer **203**, and source and drain electrodes **205** connected to the semiconductor layer **204** in the source and drain regions. Layers **201** and **206** are a buffer layer and a planarized insulating layer, respectively.

FIG. **3** is a schematic plan view of the pixel region **110** illustrating the organic light emitting layer **223** of FIG. **2**. A plurality of pixel units **200** are arranged in row and column directions.

The plurality of pixel units **200** include red, green and blue pixel units **200R**, **200G** and **200B**. An organic light emitting layer **223R** of light emitting devices **220** of red pixel units **200R** is formed in a substantially rectangular shape on the pixel defining layer **222**. Anode electrodes **221** are arranged in a column of red pixel units **200R**. An organic light emitting layer **223G** of light emitting devices **220** of green pixel units **200G** is formed in a substantially rectangular shape on the pixel defining layer **222**. Anode electrodes **221** are arranged in a column of green pixel units **200G**. An organic light emitting layer **223B** of light emitting devices **220** of blue pixel units **200B** is formed in a substantially rectangular shape on the pixel defining layer **222**. Anode electrodes **221** are arranged in a column of blue pixel units **200B**.

In some embodiments, the pixel defining layer **222** may not be provided. In this case, the organic light emitting layer **223R** of light emitting devices **220** of red pixel units **200R** is formed in a substantially rectangular shape on the insulating layer **206** and anode electrodes **221** arranged in a column of red pixel units **200R**. In addition, the organic light emitting layer **223G** of light emitting devices **220** of green pixel units **200G** is formed in a substantially rectangular shape on the insulating layer **206** and anode electrodes **221** arranged in a column of green pixel units **200G**. Furthermore, an organic

light emitting layer **223B** of light emitting devices **220** of blue pixel units **200B** is formed in a substantially rectangular shape on the insulating layer **206** and anode electrodes **221** arranged in a column of blue pixel units **200B**.

FIGS. **4A** to **4F** are cross-sectional views illustrating a method of manufacturing an organic light emitting display device according to an embodiment. FIGS. **4A** to **4F** show cross-sections taken along line **11-12** of FIG. **3** at various stages in the method.

Referring to FIG. **4A**, a planarizing insulating layer **206** is formed on a substrate **100** where TFTs **210** are formed in respective red, green and blue pixel units **200R**, **200G** and **200B** as shown in FIG. **2**. A via hole is formed so that a source or drain electrode **205** is exposed therethrough. An anode electrode **221** is formed to connect to the source or drain electrode **205** through the via hole.

Referring to FIG. **4B**, a pixel defining layer **222** is formed on the substrate **100** having the anode electrodes **221** and is patterned so that the anode electrodes **221** in light emitting regions are exposed. Subsequently, a red light emitting layer **223R** is formed on the pixel defining layer **222** having the anode electrodes **221**.

Referring to FIG. **4C**, the red light emitting layer **223R** remains in a substantially rectangular shape in only the column of the red pixel units **200R** because the red light emitting layer **223R** has been removed elsewhere.

Referring to FIG. **4D**, after a green light emitting layer **223G** is formed on the entire surface of the substrate **100** having the red light emitting layer **223R**, the green light emitting layer **223G** remains in a substantially rectangular shape in only the column of the green pixel units **200G** because the green light emitting layer **223G** has been removed elsewhere.

Referring to FIG. **4E**, after a blue light emitting layer **223B** is formed on the entire surface of the substrate **100** having the red and green light emitting layers **223R** and **223G**, the blue light emitting layer **223B** remains in a substantially rectangular shape in only the column of the blue pixel units **200B** because the blue light emitting layer **223B** has been removed elsewhere.

Referring to FIG. **4F**, a cathode electrode **224** is formed on the entire surface of the substrate **100** having the red, green and blue light emitting layers **223R**, **223G** and **223B**.

In this embodiment, a mask having openings may be used so that the pixel region **110** is exposed when the red, green and blue light emitting layers **223R**, **223G** and **223B** are formed. In this case, since the mask has the openings with a simple shape, the mask can be easily manufactured. Since the red, green and blue light emitting layers **223R**, **223G** and **223B** are all formed using the same mask, manufacturing cost can be saved.

A laser may be used for selectively removing the temporary portions of the red, green and blue light emitting layers **223R**, **223G** and **223B**. The power, wavelength and/or irradiation time of the laser is controlled, so that only desired light emitting layers **223R**, **223G** and **223B** are selectively removed without damaging layers near the light emitting layers **223R**, **223G** and **223B**. Alternatively, a passivation layer **231** made of a material having a slow etching speed with respect to the other layers may be formed on the red light emitting layer **223R** in the process of FIG. **4C**. A passivation layer **232** made of a material having a slow etching speed with respect to the other layers may be formed on the green light emitting layer **223G** in the process of FIG. **4D**. As a result, damage of the red and green light emitting layers **223R** and **223G** can be minimized in the process of selectively removing the green and blue light emitting layers **223G** and **223B**.

If the passivation layers **231** and **232** are formed of a conductive material, the operations of the light emitting devices **220** are not influenced even if the passivation layers **231** and **232** are not removed in the process of removing the undesired portions of the green and blue light emitting layers **223G** and **223B**.

While the present invention has been described in connection with certain exemplary embodiments, it is to be understood that the invention is not limited to the disclosed embodiments, but, on the contrary, is intended to cover various modifications and equivalent arrangements.

What is claimed is:

1. An organic light emitting display device, comprising:
  - a substrate comprising a plurality of areas arranged in rows and columns, wherein each column comprises a plurality of first pixel units, a plurality of second pixel units or a plurality of third pixel units;
  - a plurality of first electrodes formed on the areas wherein each electrode is formed in one of the plurality of first pixel units, in one of the plurality of second pixel units, or in one of the plurality of third pixel units;
  - a pixel defining layer formed on the substrate, wherein the pixel defining layer is patterned to have openings exposing the first electrodes;

- a first continuous light emitting layer formed on and across more than one of the first electrodes and the pixel defining layer in the column of the plurality of first pixel units;
  - a second continuous light emitting layer formed on and across more than one of the first electrodes and the pixel defining layer in the column of the plurality of second pixel units;
  - a third continuous light emitting layer formed on and across more than one of the first electrodes and the pixel defining layer in the column of the plurality of third pixel units; and
  - a second electrode formed on the first, second, and third continuous light emitting layers.
2. The organic light emitting display device of claim **1**, wherein the first, second and third continuous light emitting layers are each patterned in a substantially rectangular shape.
  3. The organic light emitting display device of claim **1**, wherein the first, second and third continuous light emitting layers are red, green and blue light emitting layers, respectively.
  4. The organic light emitting display device of claim **1**, further comprising a thin film transistor connected to each of the first electrodes.

\* \* \* \* \*

专利名称(译)	有机发光显示装置及其制造方法		
公开(公告)号	<a href="#">US8599113</a>	公开(公告)日	2013-12-03
申请号	US12/553894	申请日	2009-09-03
[标]申请(专利权)人(译)	三星显示有限公司		
申请(专利权)人(译)	三星移动显示器有限公司.		
当前申请(专利权)人(译)	三星DISPLAY CO. , LTD.		
[标]发明人	LHEE ZAIL HONG SANG MOK		
发明人	LHEE, ZAIL HONG, SANG-MOK		
IPC分类号	G09G3/32		
CPC分类号	H01L27/3211 H01L27/3244 H01L2227/323 H01L51/0017		
优先权	1020080110924 2008-11-10 KR		
其他公开文献	US20100117936A1		
外部链接	<a href="#">Espacenet</a> <a href="#">USPTO</a>		

摘要(译)

公开了一种有机发光显示装置及其制造方法。有机发光显示装置包括基板，在基板上沿行和列方向布置第一，第二和第三像素单元。为了简化制造并减少缺陷，第一，第二和第三像素单元被布置成使得显示器的每列仅由第一，第二和第三像素单元中的一个形成。

